

Track Pad Specifications

CLIP-ON TYPE

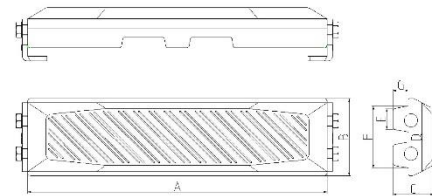
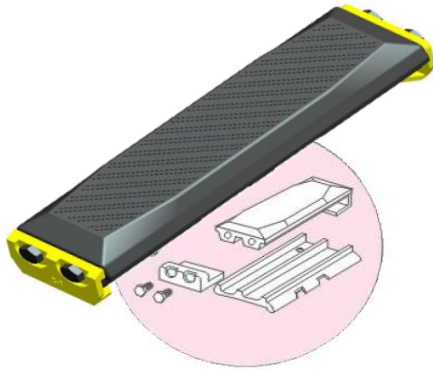

MODEL	A	B	C	D	E	F	G	weight kg
GTW C250F	252	69	48		44	49	17	1.295
GTW C300F	302	68	47.5		40	46	17.5	1.45
GTW C320F	322	71	50		47	51	18	1.575
GTW C350F	352	68	50		38	46	17.5	1.65
GTW C380F	376	106	60	16	27	85	18	3.425
GTW C400HD	392	98	53	14	30	86	18	3.1
GTW C450E	434	133	65	14	36	104	18.5	5.19
GTW C450HD	454	102	71	14	28	86	18	3.5
GTW C500A	480	132	67	13	43	111	20	6.68
GTW C500B	493	128	67	17	34	102	26	6.25
GTW C500G	480	133	70	15	33.5	102	22	6.8
GTW C600B	593	128	72	18	34.5	100	26	7.5
GTW C600G	580	132	70	16	34	102	21	7.8
GTW C600H	589	146	80	18	40	114	26	9.13
GTW C600W	596	114	63	12	27.5	81	20	5.6
GTW C600HD	600	132	58	12	37.5	100	19	7.31
GTW C700A	693	142	75	16.5	45	121	26	9.195
GTW C700B	693	138	75	20	32	102	26	8.75
GTW C700D	700	140	69	15	32.5	100	25	9.25
GTW C700E	700	160	71	16	38	108	27	10.12
GTW C700KPC	688	160	83	17	37.5	112	27	10.75
GTW C700W	688	160	95	16	35	112	32	11.7
GTW C800	793	168	104.5	21	42	135	37	17.85
GTW C800KPC	789	156	88.5	27	35	110	27	12.65

BOLT-ON TYPE

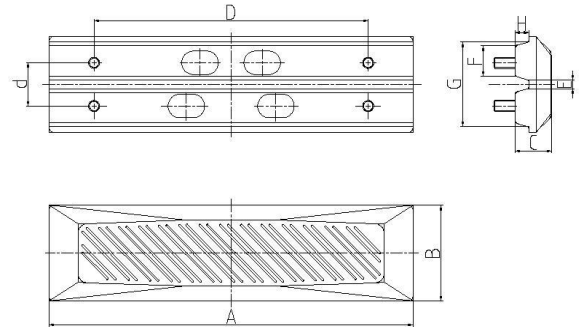
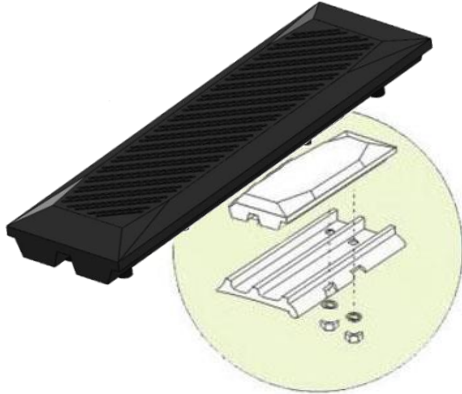

MODEL	A	B	C	D*d	E	F	G	H	weight kg
GTW B300	300	67	36.5	200		42	54	15	1.05
GTW T300	295	125	57	220*57	19	34	97	22	2.41
GTW B350	350	68	37.5	200		46	53	15	1.25
GTW B350Y(A/B)	350	107	40	290*46	9.8	35.5	90	10.5	1.9
GTW B400B	395	102	38	300*46	9	32.5	90	16	2.03
GTW B400D(L/R)	398	103	37	300*46	10	29	89	14	2.05
GTW B400G	400	102	45	300*45	8	28	84	18	2.3
GTW B400-1	390	108	37	300*46	9	33	90	14.3/10.6	2.1
GTW B450A	450	105	38.5	350*45	12	29	91	14.5	2.49
GTW B450B	450	123	44.5	350*57	9	37	101	18.5	3.2
GTW B450D	445	122	45	350*58	10	35.5	110	21	3.2
GTW B450G	445	101	45	350*46	7	30	81	18	2.6
GTW B450Y	450	115	43	350*58	16	31	91	18.5	2.89
GTW B450-1	440	125	48	350*58	10.5	41	108	21.5	3.4
GTW B475(L/R)	475	133	41	350*60	13	42	114.5	21	3.63
GTW B475Y-N	475	133	46	350*60	12	37	103	26	3.76
GTW B500	496	122	56	400*56	14	34	106	27	4.4
GTW B500A	495	137	48	400*60	17	44	115	18	4.38
GTW B500B	495	121	56	400*56	12	33	104	27	4.4
GTW B500D	495	125	53	400*60	14	36	114	19	4.28
GTW B500-1	490	133	55	400*60	14	47	115	20	4.7
GTW B530	530	140	71	400*60	16	42	114	19.2	6.95
GTW B600	595	134	71	400*70	15.4	45	124	25.5	7.5
GTW B600B	593	134	55.5	400*58	17	40	120	26.8	5.65
GTW B600G	590	134	56.7	400*60	14	33	104	20	5.5

CHAIN-ON TYPE

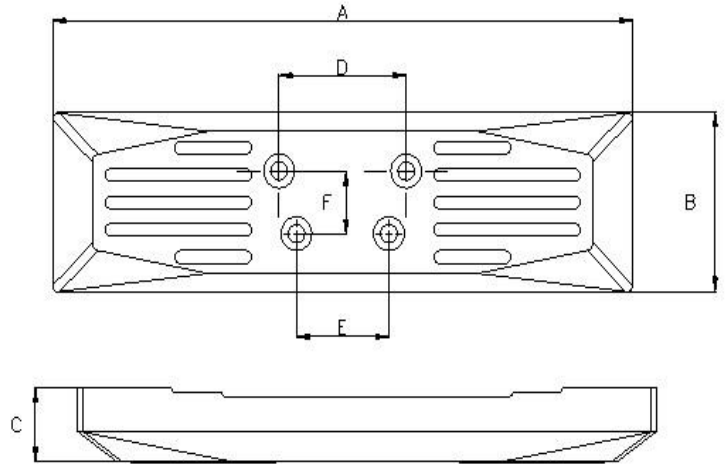
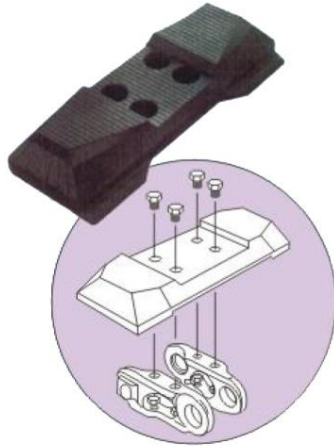

MODEL	A	B	C	Bolt hole	D	E	F	weight kg
GTW J300B	300	93	41	M12	144	116	22	2.1
GTW J400	400	125	51	14	94	64	46	5.7
GTW J400A	400	125	52	14	100	73	45	5.835
GTW J400E	400	126	51.5	14.5	104	80	46	5.655
GTW J450	453	147	52	15	89	73	57	8.05
GTW J450A	450	126.5	51.5	13.8	99	72	44	7.83
GTW J450B	450	145	52	15	90	90	46	9.5
GTW J450D	450	148	50	15	90	90	55	7.535
GTW J450E	450	147	51	15	83	83	52	8.05
GTW J450F-NS	450	145	65.5	14.8	90	90	57	8.15
GTW J450Y	450	120	47	15.5	88	72.5	56	6.5
GTW J475Y	475	140	51	17.5	109	109	60	8.395
GTW J500	500	160	59	18	108	108	60.5	12.25
GTW J500B	500	162	58.5	18.5	102	86	57	12.45
GTW J500-NS	500	162	74	18	108	108	60	13.8

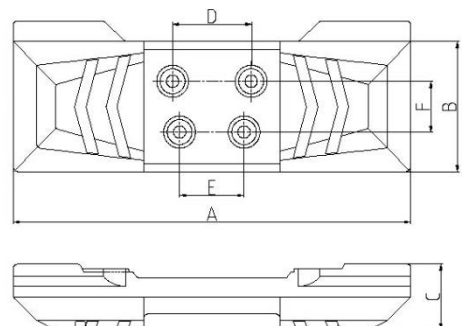
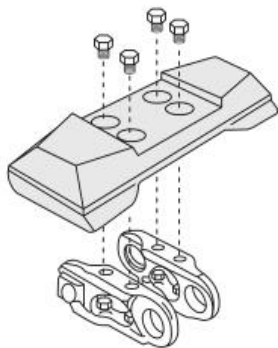

MODEL	A	B	C	Bolt	D	E	F	weight kg
GTW J450C	450	146	74	14.5	89	73	57	9.5